

Installation, operating,
and maintenance
manual



Water chillers



Air/water
self-contained



Axial fans and
scroll compressors

CE
0062

ZETA 2002 - water chiller

Air-cooled liquid chillers with hermetic scroll compressors and plate type evaporator, suitable for outdoor installations. The unit has a refrigerant circuit for each pair of compressors.

UNIT FRAME

Self supporting frame with removable panels, internally coated with expanded polyurethane sound-absorbing material; constructed from galvanized sheet steel with RAL 5014 powder paint baked at 180°C to provide a durable weatherproof finish. Threaded fasteners in stainless steel.

COMPRESSORS

Hermetic scroll type with orbital motion, connected in tandem and equipped with oil level sight glass, Klixon internal thermal protection and oil equalisation line.

The compressors are housed in a sound insulated compartment and separated from the air flow; access is provided by removable panels which allow maintenance work to be performed in safety even when the unit is in operation.

CONDENSER

Composed of a high efficiency coil manufactured from copper tubes and aluminium fins. The finned coil is protected by a metal grille which is installed as standard.

CONDENSER FANS

Axial fans directly coupled to 6 pole motors with internal Klixon overload protection.

Motor protection category is IP 54. The fan is equipped with a safety grille to UNI EN 294.

EVAPORATOR

Brazed plate type in 316 AISI stainless steel. Thermal insulation of evaporator is provided by closed cell expanded material. Each evaporator is equipped with a low water temperature probe for freeze protection and each unit is equipped as standard with a mechanical flow switch.

REFRIGERANT CIRCUIT

Comprising: liquid valve, charge connection, liquid sight-glass, filter/dryer, thermostatic expansion valve with external pressure equalisation, high and low pressure switches for 2-compressor models.

For 4-compressor models high and low pressure values and relative condensation and evaporation temperatures are measured by pressure transducers that relay the signals to the controller so that they can be read directly on the display. The high pressure side of the circuit is equipped with high pressure switches and relief valves.

ELECTRICAL PANEL

The electrical panel includes:

- main switch
- thermal magnetic circuit-breakers for fans and (if present) pumps; compressor fuses for the power circuit
- compressor contactors
- fan contactors
- pump contactors (ST version)

The microprocessor controls the following functions on all units:

- water temperature regulation
- freeze protection
- compressor time intervals
- compressor start sequence and automatic lead/lag selection
- alarm reset
- common alarm contact for remote signalling
- operating and alarm indicator LEDs

LCD display of the following information:

- water inlet and outlet temperature
- programmed temperature set-point and differential
- alarms description
- compressor hours run meter

for 4 compressor units:

- number of starts of the unit and the compressors
- high and low pressure values and relative condensation and evaporation temperature values.

Electrical power supply [V/f/Hz]: 400/3~/50 ±5%

CONTROLS AND SAFETY DEVICES

- chilled water temperature probe (at evaporator inlet)
- freeze protection probe at the outlet of each evaporator
- safety high pressure switch with manual reset
- low pressure switch (with manual reset controlled by the control)
- high pressure relief valve
- compressor over-temperature protection
- fan over-temperature protection
- mechanical flow switch, supplied as standard on all units, as kit for units 3.2 to 13.2 and factory installed for units 14.4 to 26.4.

TESTING

The units are subjected to a dry run in the factory and supplied complete with oil and refrigerant.

ZETA UNIT VERSIONS

ZETA 2002 /HP: reverse cycle heat pump

The heat pump version operates as a air cooled chiller in summer and a air to water heat pump in winter by reversing the refrigerant flow to suit the required operating mode.

- Refrigerant circuit:
 - 4-way reversing valve, liquid receiver, second thermostatic valve.
- Electrical panel:
 - Microprocessor enabled for summer/winter changeover and automatic defrosting.

ZETA 2002 LE: condensing unit.

The basic ZETA 2002 model is not equipped with an evaporator or thermostatic valve.

Also the four compressor models are not supplied with a microprocessor controller. Liquid receivers can be supplied as an accessory. The solenoid valve on the liquid line is supplied as standard.

ZETA 2002 LE /HP: heat pump condensing unit.

The basic ZETA 2002/HP model is not equipped with an evaporator, a thermostatic valve and four compressor models are not supplied with a microprocessor controller. Liquid receivers can be supplied as an accessory. The solenoid valve on the liquid line is supplied as standard.

HYDRAULIC MODULE OPTIONS

ZETA 2002 /ST 2PS : unit with storage tank and pumps.

In addition to the components of version ZETA 2002, this unit includes:
insulated storage tank; run and standby circulating pumps, with automatic changeover for four compressor models and manual changeover for two compressor models;
Also provided are an expansion tank, check valves and gate valves.

Version ST is available in the following additional four configurations:

- ST 1PS : with 1 pump and tank;
- ST 2P : with 2 pumps and no tank;
- ST S : with tank and no pumps;
- ST 1P : with 1 pump and no tank.

ACCESSORY VERSIONS

ZETA 2002 /DC: unit with heat recovery condenser.

Not available for HP versions.

This accessory is available for the following models: 3.2-13.2 " 1p-2p" 18.4-26.4" s" .

In addition to the components of version ZETA 2002, this unit includes a 100% heat recovery condenser for the production of hot water, a recovery water temperature control thermostat, and a recovery circuit safety pressure switch.

ZETA 2002 /DS: unit with desuperheaters

The brazed plate type desuperheater is arranged in series with the condensing coil. It is available for the following models: from 3.2 to 13.2 with " 1p-2p" and from 14.4 to 26.4 " 1p-2p-1ps-2ps-s" .

It is also available in the HP configuration. In this case the installation must be fitted with a shut-off valve on the water recovery circuit, to be closed during heat pump mode operation as described in the manual.

ZETA 2002 /LN: low noise unit

In addition to the components of version ZETA 2002, this unit includes:

galvanised sheet steel compressor compartment with full sound insulation using expanded polyurethane sound absorption material and expanded polyurethane with an intermediate layer of high acoustic impedance material applied to the sides of the compartment.

ZETA 2002 /SLN: extra low noise unit

In addition to the components of version LN, this unit is designed to operate with a slower fan speed to further reduce noise levels.

REFRIGERANT CIRCUIT ACCESSORIES:

- **Step type condensing pressure control**
(ambient air minimum temperature 0 °C).
The control is managed in On/Off mode by the microprocessor by means of the pressure transducers.
Available for models 18.4 to 26.4 only.
- **Condensing pressure control by fan speed regulator**
(ambient air minimum temperature -20 °C).
Fan speed is regulated in accordance with the condensation pressure read by the pressure transducers.
Available for all models.
- **Dual set-point.**
With double thermostatic valves + solenoid valves. In units with two compressors the set-point must be modified manually on the controller. For four compressor units two set-points can be programmed and switched between them from the keypad or using a digital input. The type of selection must be specified at the time of the order. In all cases the thermostatic valves switch automatically on the basis of the water temperature.
- **Pressure gauges.**
Available for all models. Note however that on 4-compressor units the suction and discharge pressure values are read by transducers that relay the results to the controller display.
- **Liquid receivers**
(standard on versions /HP and /HP/LE)
- **Compressor suction and discharge valves**
- **Liquid line solenoid valve**

HYDRAULIC CIRCUIT ACCESSORIES

- **Leaving water temperature control.**
Available only on 4-compressor models (not HP versions).
- **Anti-freeze heater**
- **Water side relief valve** (version ST only).
The value is set at 6 bar, corresponding to the maximum permissible working pressure.

ELECTRICAL ACCESSORIES

- **Serial interface:**
 - 2-compressor units are equipped with RS485 type serial interface with Carel protocol.
 - 4-compressor units are equipped with RS485 type serial interface with Modbus protocol; the following optional protocols are available on request: Carel; Echelon in version RS485 or in version FTT10
- **Power factor correction $\cos \phi \geq 0.9$** at nominal operating conditions
- **Single voltage-free contacts for machine status signals**
- **Set-point variable in a range of 3 °C with remote signal** (0-1V, 0-10V, 0-4mA, 0-20mA).
Available only for models from 16.4 to 26.4
- **Remote user terminal panel** (in addition to the standard terminal)

SERIES

The ZETA 2002 series of water cooled chillers and heat pumps, are available in various sizes with capacities from 38 to 266 kW.

Model designations consist of two numbers:

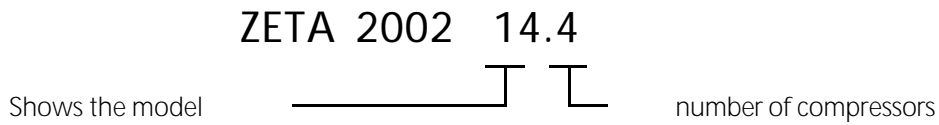

The model, serial number, characteristics, power supply, etc. are shown by means of decals on the unit.

		Via Enrico Mattei, 20 35028 Piove di Sacco (PD) ITALY Tel. +039.049.9716300		0062
Modello/Model Modell/Modèle		Matricola/Serial number (BBOX) Matrikel/Matricule		
Tensione-Fasi-Frequenza Voltage-Phases-Frequency Spannung-Phases-Frequenz Tension-Phases-Fréquence		Tensione circuiti ausiliari Auxiliary circuit voltage Steuerspannung Tension circuits auxiliares		
Corrente massima assorbita Max absorbed current Maximalstromverbrauch Courant maxi absorbée		Corrente massima di spunto Max starting current Max. Anlaufstrom Courant maxi démarrage		
Tipo refrigerante Refrigerant type Kältemittel Typ Type de refrigerant		IP quadro elettrico IP electrical board IP E-Schrank IP tableau électrique		
Numero circuiti refrigerante Refrigerant circuit number Anzahl des Kältemittelkreislaufes Numero circuits refrigerant		Press. massima circuito refriger. Max. Refrigerant circuit pressure Max. Druck Kältekreislauf Pression maxi circuit refrigerant		
Press. massima circuito idraulico Max. Hydraulic circuit pressure Max. Druck im Hydraul. Kreislauf Pression maxi circuit hydraulique		Data di produzione Manufacturing date Erstellungsdatum Date de fabrication		
Carica refrigerante per circuito(kg)/Refrigerant charge per circuit(kg) /Kältemittelfüllung Kreislauf(kg)/Charge de refrigerant chaque circuit(kg)		kPa bar		
C1	C2	C3	C4	

		Via Enrico Mattei, 20 35028 Piove di Sacco (PD) ITALY Tel. +039.049.9716300		0062
MODELLO - MODELE - MODEL - TYP				
MATRICOLA - MATRICULE - SERIAL NO. - SERIENUMMER				
REFRIGERANTE - REFRIGERANT - KÄLTEMITTEL - REFRIGERANT				

MODELLO
MATRICOLA
REFRIGERANTE
ESECUZIONE SECONDO NORMATIVE
SCHEMA ELETTRICO
SCHEMA FRIGORIFERO
SCHEMA IDRAULICO
DISEGNO MECCANICO

MODELLO MODELE MODEL -TYP
MATRICOLA - MATRICULE SERIAL NO. - SERIENUMMER

TECHNICAL DATA

R407C refrigerant

MODEL ZETA 2002		18.4	20.4	24.4	26.4
Cooling (*)					
Nominal capacity	kW	185,8	211	235,8	260,7
Evaporator water flow	l/s	8,88	10,08	11,27	12,45
	l/h	31.965	36.296	40.565	44.834
Evaporator pressure drop	kPa	62	63,8	71,1	70,6
Heating (**)					
Nominal capacity	kW	185,3	213,3	239,1	264,9
Condenser water flow	l/s	8,85	10,19	11,42	12,66
	l/h	31.873	36.686	41.122	45.558
Condenser pressure drop	kPa	61,6	65,1	73	72,8
Compressors		type	scroll		
Quantity	n	4	4	4	4
Refrigerant circuits	n	2	2	2	2
Absorbed power cooling (*)	kW	61,2	72	80	88,1
Absorbed power heating (**)	kW	64,2	73,3	81,1	88,8
Capacity steps	%	0-25-50-75-100	0-25-50-75-100	0-25-50-75-100	0-25-50-75-100
Condenser cooling fans		type	axial		
Total air flow	m ³ /s	16,38	16,42	19,39	18,50
	m ³ /h	58.950	59.100	69.800	66.600
Fan motor power	n x kW	3 x 2,0	3 x 2,0	4 x 2,0	4 x 2,0
Nominal revolution speed	RPM	880			
Electric motor supply	V/Ph/Hz	400/3~/50			
Refrigerant charge					
Chiller version	kg	2 x 27	2 x 27	2 x 26	2 x 31,5
Heat pump version	kg	2 x 30	2 x 30	2 x 30	2 x 35
Oil					
Oil charge	l	2 x 8 + 2 x 6,6	4 x 8	4 x 8	4 x 8
Oil producer		Maneurop			
Oil type		160 SZ			
Evaporator		type	plate		
Heat exchanger water volume	l	6,3	7,3	8,4	9,4
Max operating pressure water side	bar	30			
Dimension and weight					
Length	mm	4.234	4.234	4.234	4.234
Width	mm	1.119	1.119	1.119	1.119
Height	mm	2.380	2.380	2.380	2.380
Shipping weight	kg	1.930	2.089	2.208	2.349

(*) ambient air temperature 35°C; evaporator entering/leaving water temperature 12-7 °C;.

(**) ambient air temperature 8°C DB, 70%RH; condenser entering/leaving water temperature 40-45 °C.

TECHNICAL DATA - ELECTRICAL CHARACTERISTICS AND COMPONENTS

R407C refrigerant

Maximum absorbed power ⁽¹⁾	kW	53,4	58,4	64,4	76,4
	kW	(55,6)	(60,6)	(66,6)	(78,6)
Maximum starting current	A	328,1	347,1	288	288
	A	(333,4)	(352,4)	(293,3)	(293,3)
Full load current ⁽²⁾	A	127,1	146,1	148	148
	A	(132,4)	(151,4)	(153,3)	(153,3)
Fan motor nominal power	n x kW	3 x 0,6	3 x 0,6	2 x 2,0	2 x 2,0
Fan motor nominal absorbed current	n x A	3 x 2,7	3 x 2,7	2 x 4,0	2 x 4,0
Pump motor nominal power	kW	(1 x 2,2)	(1 x 2,2)	(1 x 2,2)	(1 x 2,2)
Pump motor nominal absorbed power	A	(1 x 5,3)	(1 x 5,3)	(1 x 5,3)	(1 x 5,3)
Power supply	V/Ph/Hz	400V 3N ~ 50Hz ±5% V			
Control power supply	V/Ph/Hz	230/~50			
Control circuit supply	V/Ph/Hz	24V ~ 50Hz			
Condenser fans supply	V/Ph/Hz	230V/~50Hz			
Pumps supply, ST groups	V/Ph/Hz	400V/3~/50			

Maximum absorbed power ⁽¹⁾	kW	88,8	99,2	111,2	121,2
	kW	(92,8)	(103,2)	(115,2)	(126,7)
Maximum starting current	A	347	377	455	493
	A	(356,5)	(386,5)	(464,5)	(505)
Full load current ⁽²⁾	A	182	212	254	292
	A	(191,5)	(221,5)	(263,5)	(304)
Fan motor nominal power	n x kW	3 x 2,0	3 x 2,0	4 x 2,0	4 x 2,0
Fan motor nominal absorbed current	n x A	3 x 4,0	3 x 4,0	4 x 4,0	4 x 4,0
Pump motor nominal power	kW	(1 x 4,0)	(1 x 4,0)	(1 x 4,0)	(1 x 5,5)
Pump motor nominal absorbed power	A	(1 x 9,5)	(1 x 9,5)	(1 x 9,5)	(1 x 12,0)
Power supply	V/Ph/Hz	400V 3N ~ 50Hz ±5% V			
Control power supply	V/Ph/Hz	230/~50			
Control circuit supply	V/Ph/Hz	24V ~ 50Hz			
Condenser fans supply	V/Ph/Hz	400V/3~/50			
Pumps supply, ST groups	V/Ph/Hz	400V/3~/50			

(1) mains power supply to allow unit operation.

(2) maximum current before safety cut-outs stop the unit. This value is never exceeded and must be used to size the electrical supply cables and relevant safety devices (refer to electrical wiring diagram supplied with the unit).

All values in brackets are refer to /ST version (units with storage tank) or units with pump.

TECHNICAL DATA - ZETA 2002 /ST 2PS

R407C refrigerant

MODEL ZETA 2002		3.2	4.2	5.2	6.2
Pump section					
Evaporator water flow	l/s	1,77	2,13	2,45	2,88
	l/h	6.377	7.682	8.833	10.379
Pump nominal power	kW	0,5	0,5	0,5	1,1
External available pressure	kPa	117	103	96	139
Storage tank water volume	l	200	200	200	200
Dimension and weight					
Length	mm	2.233	2.233	2.233	2.233
Width	mm	1.043	1.043	1.043	1.043
Height	mm	1.740	1.740	1.740	1.740
Shipping weight	kg	724	734	755	807

MODEL ZETA 2002		7.2	8.2	9.2	10.2
Pump section					
Evaporator water flow	l/s	3,23	3,71	4,37	4,89
	l/h	11.608	13.347	15.748	17.611
Pump nominal power	kW	1,1	1,1	1,5	1,5
External available pressure	kPa	134	112	122	109
Storage tank water volume	l	200	200	450	450
Dimension and weight					
Length	mm	2.233	2.233	3.234	3.234
Width	mm	1.043	1.043	1.144	1.144
Height	mm	1.740	1.740	1.740	1.740
Shipping weight	kg	825	868	1.142	1.219

MODEL ZETA 2002		12.2	13.2	14.4	16.4
Pump section					
Evaporator water flow	l/s	5,63	6,05	6,55	7,53
	l/h	20.283	21.780	23.567	27.103
Pump nominal power	kW	2,2	2,2	2,2	2,2
External available pressure	kPa	115	110	134	96
Storage tank water volume	l	450	450	340	340
Dimension and weight					
Length	mm	3.234	3.234	3.234	3.234
Width	mm	1.144	1.144	1.119	1.119
Height	mm	1.740	1.740	2.380	2.380
Shipping weight	kg	1.275	1.309	1.642	1.678

MODEL ZETA 2002		18.4	20.4	24.4	26.4
Pump section					
Evaporator water flow	l/s	8,88	10,08	11,27	12,45
	l/h	31.965	36.296	40.565	44.834
Pump nominal power	kW	4	4	4	5,5
External available pressure	kPa	138	124	101	159
Storage tank water volume	l	700	700	700	700
Dimension and weight					
Length	mm	5.234	5.234	5.234	5.234
Width	mm	1.119	1.119	1.119	1.119
Height	mm	2.380	2.380	2.380	2.380
Shipping weight	kg	2.290	2.449	2.622	2.749

SOUND POWER AND PRESSURE LEVELS

STANDARD UNITS

ZETA 2002	Octave band [Hz]																Total	
	63		125		250		500		1000		2000		4000		8000		dB(A)	
	Lw	Lp	Lw	Lp	Lw	Lp	Lw	Lp	Lw	Lp	Lw	Lp	Lw	Lp	Lw	Lp	Lw	Lp
3.2	96,1	78,8	87,3	70,0	81,2	63,8	79,7	62,4	78,6	61,3	73,2	55,9	69,8	52,4	60,7	43,4	83,0	65,7
4.2	96,5	79,1	87,7	70,3	81,5	64,2	80,0	62,7	78,9	61,6	73,6	56,2	70,1	52,8	61,0	43,7	83,3	66,0
5.2	96,6	79,2	87,8	70,4	81,6	64,3	80,1	62,8	79,0	61,7	73,7	56,3	70,2	52,9	61,1	43,8	83,4	66,1
6.2	97,3	79,9	88,5	71,1	82,3	65,0	80,8	63,5	79,7	62,4	74,4	57,0	70,9	53,6	61,8	44,5	84,1	66,8
7.2	97,5	80,1	88,7	71,3	82,5	65,2	81,0	63,7	79,9	62,6	74,6	57,2	71,1	53,8	62,0	44,7	84,3	67,0
8.2	98,1	80,8	89,3	72,0	83,2	65,8	81,7	64,4	80,6	63,2	75,2	57,9	71,8	54,4	62,7	45,3	85,0	67,7
9.2	99,7	81,8	90,9	73,0	84,8	66,8	83,3	65,4	82,2	64,2	76,9	58,9	73,4	55,4	64,3	46,3	86,6	68,7
10.2	100,0	82,0	91,2	73,2	85,0	67,0	83,5	65,6	82,4	64,5	77,1	59,1	73,6	55,6	64,5	46,6	86,8	68,9
12.2	100,1	82,2	91,3	73,4	85,1	67,3	83,7	65,8	82,6	64,7	77,2	59,3	73,7	55,9	64,7	46,8	87,0	69,1
13.2	100,3	82,3	91,5	73,5	85,3	67,3	83,8	65,9	82,7	64,8	77,4	59,4	73,9	55,9	64,8	46,9	87,1	69,2
14.4	101,1	82,5	92,3	73,7	86,1	67,5	84,6	66,0	83,5	64,9	78,2	59,6	74,7	56,1	85,6	47,0	87,9	69,3
16.4	103,6	85,0	94,8	76,2	88,6	70,1	87,2	68,6	86,1	67,5	80,7	62,1	77,2	58,7	68,2	49,6	90,5	71,9
18.4	104,5	85,4	95,7	76,6	89,6	70,5	88,1	69,0	87,0	67,9	81,6	62,5	78,2	59,1	69,1	50,0	91,4	72,3
20.4	105,2	86,1	96,4	77,3	90,3	71,2	88,8	69,7	87,7	68,6	82,3	63,2	78,9	59,8	69,8	50,7	92,1	73,0
24.4	106,1	87,0	97,3	78,2	91,2	72,1	89,7	70,6	88,6	69,5	83,2	64,1	79,8	60,7	70,7	51,6	93,0	73,9
26.4	106,2	87,1	97,4	78,3	91,3	72,2	89,8	70,7	88,7	69,6	83,3	64,2	79,9	60,8	70,8	51,7	93,1	74,0

LOW NOISE UNITS

ZETA 2002 /LN	Octave band [Hz]																Total	
	63		125		250		500		1000		2000		4000		8000		dB(A)	
	Lw	Lp	Lw	Lp	Lw	Lp	Lw	Lp	Lw	Lp	Lw	Lp	Lw	Lp	Lw	Lp	Lw	Lp
3.2	93,4	76,0	84,6	67,2	78,4	61,1	76,9	59,6	75,8	58,5	70,5	53,1	67,0	49,7	57,9	40,6	80,2	62,9
4.2	93,5	76,2	84,7	67,4	78,5	61,3	77,0	59,8	75,9	58,7	70,6	53,3	67,1	49,9	58,0	40,8	80,3	63,1
5.2	93,7	76,4	84,9	67,6	78,7	61,5	77,2	60,0	76,1	58,9	70,8	53,5	67,3	50,1	58,2	41,0	80,5	63,3
6.2	94,3	77,0	85,5	68,2	79,3	62,1	77,8	60,6	76,7	59,5	71,4	54,1	67,9	50,7	58,8	41,6	81,1	63,9
7.2	94,4	77,1	85,6	68,3	79,4	62,2	77,9	60,7	76,8	59,6	71,5	54,2	68,0	50,8	58,9	41,7	81,2	64,0
8.2	96,3	79,0	87,5	70,2	81,3	64,1	79,8	62,6	78,7	61,5	73,4	56,1	69,9	52,7	60,8	43,6	83,1	65,9
9.2	97,3	79,0	88,5	70,6	82,3	64,5	80,9	63,0	79,8	61,9	74,4	56,5	70,9	53,1	61,9	44,0	84,2	66,3
10.2	97,8	79,5	89,0	71,1	82,8	65,0	81,4	63,5	80,3	62,4	74,9	57,0	71,4	53,6	62,4	44,5	84,7	66,8
12.2	97,3	79,0	88,5	70,6	82,3	64,5	80,9	63,0	79,8	61,9	74,4	56,5	70,9	53,1	61,9	44,0	84,2	66,3
13.2	97,6	79,3	88,8	70,9	82,6	64,8	81,2	63,3	80,1	62,2	74,7	56,8	71,2	53,4	62,2	44,3	84,5	66,6
14.4	99,1	80,5	90,3	71,7	84,1	65,5	82,6	64,0	81,5	62,9	76,2	57,6	72,7	54,1	63,6	45,0	85,9	67,3
16.4	101,8	82,6	93,0	74,4	86,8	68,3	85,4	66,8	84,3	65,7	78,9	60,3	75,4	56,9	66,4	47,8	88,7	70,1
18.4	102,6	82,7	93,8	74,7	87,7	68,6	86,2	67,1	85,1	66,0	79,7	60,6	76,3	57,2	67,2	48,1	89,5	70,4
20.4	103,0	83,1	94,2	75,1	88,1	69,0	86,6	67,5	85,5	66,4	80,1	61,0	76,7	57,6	67,6	48,5	89,9	70,8
24.4	103,9	84,0	95,1	76,0	89,0	69,9	87,5	68,4	86,4	67,3	81,0	61,9	77,6	58,5	68,5	49,4	90,8	71,7
26.4	104,0	84,1	95,2	76,1	89,1	70,0	87,6	68,5	86,5	67,4	81,1	62,0	77,7	58,6	68,6	49,5	90,9	71,8

Lw: sound power values in free field conditions are calculated in accordance with ISO 3746.

Lp : sound pressure values measured at 1 m from the unit in free field conditions in compliance with ISO 3746

SOUND POWER AND PRESSURE LEVELS

EXTRA LOW NOISE UNITS

ZETA 2002 /SLN	Octave band [Hz]																Total	
	63		125		250		500		1000		2000		4000		8000		dB(A)	
	Lw	Lp	Lw	Lp	Lw	Lp	Lw	Lp	Lw	Lp	Lw	Lp	Lw	Lp	Lw	Lp	Lw	Lp
3.2	90,2	73,0	81,4	64,2	75,3	58,1	73,8	56,6	72,7	55,5	67,3	50,1	63,9	46,7	54,8	37,6	77,1	59,9
4.2	90,6	73,5	81,8	64,7	75,7	58,6	74,2	57,1	73,1	56,0	67,7	50,6	64,3	47,2	55,2	38,1	77,5	60,4
5.2	91,1	73,9	82,3	65,1	76,2	59,0	74,7	57,5	73,6	56,4	68,2	51,0	64,8	47,6	55,7	38,5	78,0	60,8
6.2	91,8	74,6	83,0	65,8	76,9	59,7	75,4	58,2	74,3	57,1	68,9	51,7	65,5	48,3	56,4	39,2	78,7	61,5
7.2	92,1	74,9	83,3	66,1	77,2	60,0	75,7	58,5	74,6	57,4	69,2	52,0	65,8	48,6	56,7	39,5	79,0	61,8
8.2	94,8	76,8	86,0	68,0	79,9	61,9	78,4	60,4	77,3	59,3	71,9	53,9	68,5	50,5	59,4	41,4	81,7	63,7
9.2	95,0	77,1	86,2	68,3	80,1	62,2	78,6	60,7	77,5	59,6	72,1	54,2	68,7	50,8	59,6	41,7	81,9	64,0
10.2	95,7	77,8	86,9	69,0	80,8	62,9	79,3	61,4	78,2	60,3	72,8	54,9	69,4	51,5	60,3	42,4	82,6	64,7
12.2	95,3	77,4	86,5	68,6	80,4	62,5	78,9	61,0	77,8	59,9	72,4	54,5	69,0	51,1	59,9	42,0	82,2	64,3
13.2	95,6	77,7	86,8	68,9	80,7	62,8	79,2	61,3	78,1	60,2	72,7	54,8	69,3	51,4	60,2	42,3	82,5	64,6
14.4	97,1	78,1	88,3	69,3	82,1	63,1	80,6	61,6	79,5	60,5	74,2	55,2	70,7	51,7	61,6	42,6	83,5	64,9
16.4	99,6	81,0	90,8	72,2	84,7	66,1	83,2	64,6	82,1	63,5	76,7	58,1	73,3	54,7	64,2	45,6	86,5	67,9
18.4	100,1	80,9	91,3	72,1	85,2	66,0	83,7	64,5	82,6	63,4	77,2	58,0	73,8	54,6	64,7	45,5	87,0	67,8
20.4	100,7	81,5	91,9	72,7	85,8	66,6	84,3	65,1	83,2	64,0	77,8	58,6	74,4	55,2	65,3	46,1	87,6	68,4
24.4	101,6	82,5	92,8	73,7	86,7	67,6	85,2	66,1	84,1	65,0	78,7	59,6	75,3	56,2	66,2	47,1	88,5	69,4
26.4	102,3	82,7	93,5	73,9	87,4	67,8	85,9	66,3	84,8	65,2	79,4	59,8	76,0	56,4	66,9	47,3	89,2	69,6

Lw: sound power values in free field conditions are calculated in accordance with ISO 3746.

Lp : sound pressure values measured at 1 m from the unit in free field conditions in compliance with ISO 3746

1. FIELD OF APPLICATION

The equipment is designed for cooling (chiller only versions) or cooling/heating (heat pump version) water, which is usually utilised for air conditioning or refrigeration applications.
The units must be used exclusively within the operating limits specified in Section 4.

1.1 INTRODUCTION

- When installing or servicing the unit, it is necessary to strictly follow the rules described in this manual, to conform to all the items detailed on the unit labels and take any necessary precaution.
- Pressure in refrigerant circuits and danger from electrical shock can be hazardous when installing or servicing the unit.
- The warranty will be invalid if the rules described in this manual are not observed and if any modifications are made to the unit without prior authorisation of the manufacturer.



Any work on the unit must be carried out by trained people only.



Attention: before repairing or servicing the unit, ensure that the electrical supply is disconnected.

2. INSPECTION, TRANSPORT, SITE HANDLING

2.1 INSPECTION

After receiving the unit, immediately check its integrity. The unit will have left the factory in perfect condition. Therefore on receiving the unit any damage must be verbally described to the carrier and recorded on the Delivery Note before it is signed by both parties. Blue Box or their Agent must be informed as soon as possible of the extent of the damage.

The Customer should prepare a written statement and photographic evidence regarding any severe damage.

2.2 LIFTING AND SITE HANDLING

Avoid sudden movements and jolts when unloading and positioning the unit. Internal handling procedures must be conducted with care. Do not exert leverage on the components of the machine. The unit must be lifted by inserting steel tubes through the lifting attachments shown by the relative signs (yellow arrow).

The unit must be lifted by harnessing it as shown in figure 1: use ropes or straps of sufficient length and spacer bars to avoid damage to the unit's side panels and cover. Alternatively, the unit (with a maximum length less than 3.5 m) can be lifted by a forklift truck, inserting the forks under the pallet.

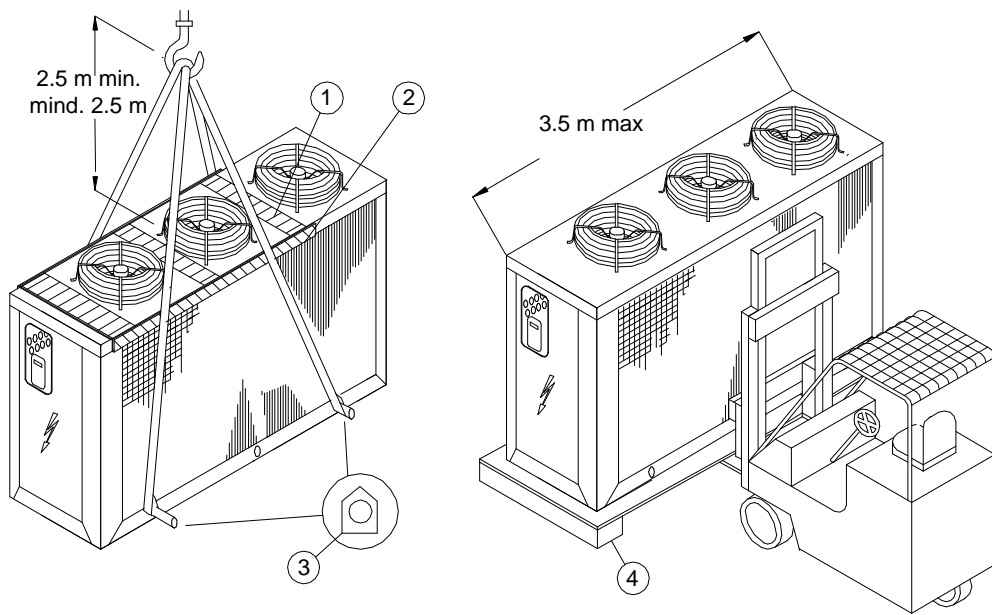

- (1) Space bar (not supplied)
- (2) Side panel protection (not supplied)
- (3) Lifting holes
- (4) Pallet

Figure 1



Caution: ensure that the method of lifting does not allow the unit to slip from chains and slings and does not allow the unit to turn over or slide from lifting devices.

2.3 UNPACKING

When unpacking the unit pay attention not to damage the unit.
 Packaging consists of different materials: wood, paper, nylon etc.
 Separate the materials and deliver to the proper gathering centre in order to reduce their environmental impact.

BLUE BOX srl
is an associate company of
BLUE BOX GROUP

BLUE BOX srl
Via E. Mattei, 20
35028 Piove di Sacco PD Italy
Tel. +39.049.9716300
Fax +39.049.9704105

BLUE BOX GROUP
on the internet

www.blueboxgroup.it

Info@blueboxgroup.it